

SUPPLY

DRAINAGE

SUPPORT

APPENDIX



869-6P



869-2P

## DWV Backwater Valve

PVC or ABS Solvent Weld Connection

- Threaded access seals hand-tight and allows for easy maintenance and inspection
- 6" backwater valve extensions – use 10" Sch. 40 pipe (not included)
- For GRAVITY FLOW applications only
- Do not install vertically
- UPC/IAPMO listed

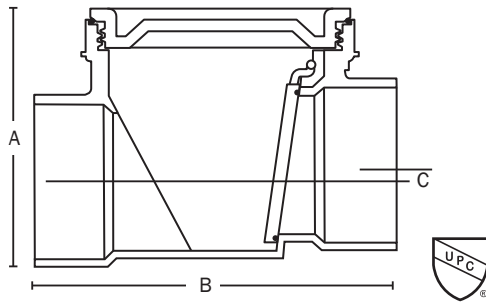

Item No	Description	Dimensions			Pkg	Min Qty	Case Qty
		A	B	C			
869-2P	2" PVC valve	4 $\frac{1}{8}$ "	5 $\frac{1}{8}$ "	$\frac{1}{4}$ "	B	1	8
869-2A	2" ABS valve	4 $\frac{1}{8}$ "	5 $\frac{1}{8}$ "	$\frac{1}{4}$ "	B	1	8
869-6P	6" PVC valve	9 $\frac{3}{4}$ "	15 $\frac{3}{8}$ "	$\frac{3}{8}$ "	B	1	1
869-6A	6" ABS valve	9 $\frac{3}{4}$ "	15 $\frac{3}{8}$ "	$\frac{3}{8}$ "	B	1	1
REPLACEMENT PARTS							
869-23	Extension sleeve kit for 2" valve includes sleeve, locking collar and lid				B	1	1
869-6A1	6" black ABS threaded lid				B	1	2
869-6P1	6" white PVC threaded lid				B	1	2
869-60	O-ring for 6" threaded lid				B	1	10
869-61	Flapper and o-ring for 6" valve				B	1	10
869-63	Extension sleeve lid for 6" valve				B	1	15

## Backup Float Valve

- Insert valve into pipe below drain and tighten screws



803-2PK2

Item No	Description	Pkg	Min Qty	Case Qty
803-2PK2	2" Backup float valve, bagged	C*	12	12
803-3PK2	3" Backup float valve, bagged	C*	12	12
803-4PK2	4" Backup float valve, bagged	C*	12	12